

## L0MQ0301 Obelix Danfoss Proportional Solenoid Module Ex ib Intrinsically Safe I/O Type C

The Obelix Mining PLC I.S. I/O Module provides intrinsically safe (Group I Ex ib) input and output resources in a single, compact unit.

A unique fiber-optic communications interface means that the module and dedicated I.S power supply can be conveniently segregated into its isolated zone.

The fibre-optic link between the module and an Obelix processor module provides real-time control and monitoring of all I/O points.

This solution is ideal for mobile mining equipment where limited installation space must be managed.

Uniquely Keyed Type Connectors to prevent incorrect machine installation.

**The module is Dual Obelix Type which complies with AS/NZS 4240 standard.**

**As per standard every output includes two switches A&B in series with monitoring feedbacks from both.**

**Extra safety is achieved by using two potted boards where each includes main and watchdog processors monitoring correctness of executed main software code.**

**Module Primary board - C25\_B0MQP**

**Module Secondary board – C19\_C20\_B0L3J**



Mounting options can vary depending on customer requirements.

### Specifications

- **Module Type:** Intrinsically Safe Input / Output with Display
- **Supply:** 12VDC (+/- 10%) / 20 Watts (Max) from Approved I.S. Power Supply
- **Data Communications:** CAN interface over Obelix Fibre
- **Operating Temperature:** -20°C to +85°C all industrial components
- **Inputs 1:** 24 x I.S. Digital Inputs (12VDC)
- **Inputs 2:** 16 x I.S. Analog Inputs (4-20 mA)
- **Inputs 3:** 16 x I.S. Namur Inputs
- **Outputs:** 4 x Danfoss Proportional Solenoid Outputs (Supply 12VIS/650mA , Control 3-9V)
- **Connector 1:** Obelix Fibre
- **Connector 2:** Obelix C25 (12VDC I.S. Supply and Danfoss Proportional Solenoid Outputs)
- **Connector 3:** Obelix C19 (12VDC I.S. Supply and Namur Inputs)
- **Connector 4:** Obelix C20 (Digital Inputs and Analog Inputs)

### Heavy Duty Enclosure

- Electroless Nickel Plated
- Rugged Construction

### Mass

- 6.5kg (14.3lb)

L0MQ0301 Obelix Danfoss Proportional Solenoid Module Ex ib Intrinsically Safe I/O Type C

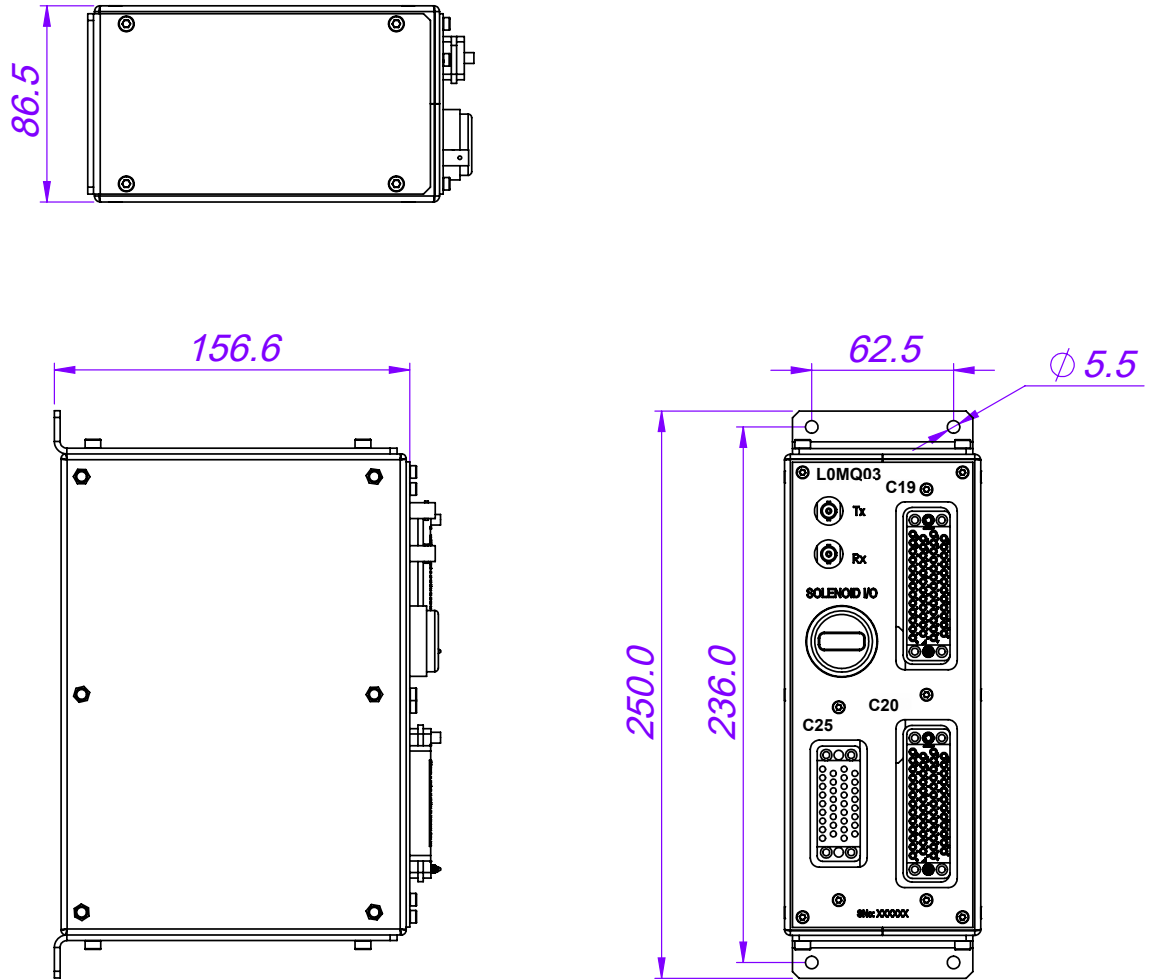

Dimensions (mm)

**L0MQ0301 Obelix Danfoss Proportional Solenoid Module Ex ib Intrinsically Safe I/O Type C**

**Display Diagnostics**

The integral 4 characters LED Matrix display provides the end-user with some basic diagnostics as to the operation of the module. These messages are as follows:

**Message Explanation Result**

**ON**

Omni Flashing Indicates nominal operation and signifies that CAN communications have been established with a host. Normal Operation Permitted

**CAN**

This indicates CAN Communication has not been established or has been lost. Outputs Disabled

**FEBK**

This indicates that internal is NOT congruent with requested outputs. This typically occurs when output has been requested but has failed to operate indicating a supply failure or wiring error. Outputs Disabled

**SHRT**

This indicates that a short-circuit condition has been detected as a requested output. This short-circuit could be external (most probable) or internal Outputs Disabled

**OPEN**

This indicates that the requested output is not drawing sufficient current to operate as expected indicating that the solenoid coil is an open circuit. Outputs Disabled



L0MQ0301 Obelix Danfoss Proportional Solenoid Module Ex ib Intrinsically Safe I/O Type C

CONNECTOR C19

Number	Unit / PCB GMCT50F Female Board Mount PIN	L0MQ0301 Name
1	A	SUPPLY-PROX-SW-1
2	B	ANALOG-1
3	C	SUPPLY-PROX-SW-2
4	D	ANALOG-2
5	E	SUPPLY-PROX-SW-3
6	F	ANALOG-3
7	H	
8	J	
9	K	SUPPLY-PROX-SW-4
10	L	ANALOG-4
11	M	
12	N	
13	P	SUPPLY-PROX-SW-5
14	R	ANALOG-5
15	S	
16	T	
17	U	SUPPLY-PROX-SW-6
18	V	ANALOG-6
19	W	SUPPLY-PROX-SW-7
20	X	ANALOG-7
21	Y	SUPPLY-PROX-SW-8
22	Z	ANALOG-8
23	a	
24	b	
25	c	SUPPLY-PROX-SW-9
26	d	ANALOG-9
27	e	
28	f	
29	h	SUPPLY-PROX-SW-10
30	j	ANALOG-10
31	k	
32	m	
33	n	SUPPLY-PROX-SW-11
34	p	ANALOG-11
35	r	SUPPLY-PROX-SW-12
36	s	ANALOG-12
37	t	SUPPLY-PROX-SW-13
38	u	ANALOG-13
39	v	
40	w	
41	x	SUPPLY-PROX-SW-14
42	y	ANALOG-14
43	z	
44	AA	
45	BB	SUPPLY-PROX-SW-15
46	CC	ANALOG-15
47	DD	SUPPLY-PROX-SW-16
48	EE	ANALOG-16
49	FF	OVIS
50	HH	12VIS



Image depict coding pins required



L0MQ0301 Obelix Danfoss Proportional Solenoid Module Ex ib Intrinsically Safe I/O Type C

CONNECTOR C20

Number	Unit / PCB GMST50F Female Board Mount PIN	L0MQ0301 Name
1	A	INP1
2	B	INP2
3	C	INP3
4	D	INP4
5	E	INP5
6	F	INP6
7	H	INP7
8	J	INP8
9	K	INP9
10	L	INP10
11	M	INP11
12	N	INP12
13	P	INP13
14	R	INP14
15	S	INP15
16	T	INP16
17	U	INP17
18	V	INP18
19	W	INP19
20	X	INP20
21	Y	INP21
22	Z	INP22
23	a	INP23
24	b	INP24
25	c	
26	d	MODULE SELECT-4
27	e	
28	f	MODULE SELECT-3
29	h	
30	j	MODULE SELECT-2
31	k	
32	m	MODULE SELECT-1
33	n	AN17
34	p	AN18
35	r	AN19
36	s	AN20
37	t	AN21
38	u	AN22
39	v	AN23
40	w	AN24
41	x	AN25
42	y	AN26
43	z	AN27
44	AA	AN28
45	BB	AN29
46	CC	AN30
47	DD	AN31
48	EE	AN32
49	FF	
50	HH	OVIS



Image depict coding pins required

**L0MQ0301 Obelix Danfoss Proportional Solenoid Module Ex ib Intrinsically Safe I/O Type C**

**CONNECTOR C25 - 4 x Danfoss Proportional Solenoid Outputs (Supply 12VIS/650mA , Control 3-9V)**

Number	Unit / PCB VMCT-34F Female Board Mount PIN	L0MQ0301 Name
1	A	
2	B	12VIS Supply Solenoid 1
3	C	
4	D	0VIS
5	E	
6	F	Control Solenoid 1_3V-9V
7	H	
8	J	0VIS
9	K	
10	L	12VIS Supply Solenoid 2
11	M	MODULE SELECT-1
12	N	0VIS
13	P	
14	R	Control Solenoid 2_3V-9V
15	S	MODULE SELECT-2
16	T	0VIS
17	U	
18	V	12VIS Supply Solenoid 3
19	W	MODULE SELECT-3
20	X	0VIS
21	Y	
22	Z	Control Solenoid 3_3V-9V
23	AA	MODULE SELECT-4
24	BB	0VIS
25	CC	
26	DD	12VIS Supply Solenoid 4
27	EE	
28	FF	0VIS
29	HH	
30	JJ	Control Solenoid 4_3V-9V
31	KK	
32	LL	0VIS
33	MM	0VIS Supply
34	NN	12VIS Supply



Image depict coding pins required

L0MQ0301 Obelix Danfoss Proportional Solenoid Module Ex ib Intrinsically Safe I/O Type C

Fibre Optic Patch Cables

Part Number	Description
H0LW0401	Fibre Optic Patch ST-ST Multi-Mode
H0M10101	Connector Assembly Fibre 8 way 7m
H0M10201	Connector Assembly Fibre 8 way 10m
H0M10301	Connector Assembly Fibre 8 way 1m
H0M10401	Connector Assembly Fibre 8 way 4m
H0M10801	Connector Assembly Fibre 8 way 8m
H0M10901	Connector Assembly Fibre 8 way 11m
H0M11001	Fibre Optic Patch Assembly 8 way 3m
H0M11201	Connector Assembly Fibre 8 way 12.5m



Image above Fibre Optic Patch ST-ST Multi-Mode

Specifications

- **Product Type:** Pre-manufactured cable assembly
- **Construction:** Fibre Optic with ST terminations
- **Connector 1 :** Fibre Optic Tx
- **Connector 2:** Fibre-optic Rx
- **Pin Type:** ST Fibre Plugs
- **Conductor Type:** Multi-mode Fibre-optic
- **Insulation Rating:** N/A
- **Temperature Rating:** -40°C to 85°C

Connector Assembly

Part Number	Description
H0MQ0701	Connector Assembly C25
H0MQ0801	Connector Assembly C19
H0MQ0901	Connector Assembly C20



Specifications

- **Product Type:** Pre-manufactured cable assembly
- **Construction:** Connector with flying leads (pigtail)
- **Pin Type:** Male (Gold-plated)
- **Conductor Type:** PVDF Tinned Stranded Wire
- **Insulation Rating:** 600 volts
- **Temperature Rating:** -65 to 105 C
- **Recommended Tools:** PVDF / Teflon Insulation Stripping Tool

Cable options can vary depending on customer requirements.