

L0RE0201 Pempek OBP Apitech Solenoid Module Type B

The L0RE Pempek OBP Mining PLC Solenoid Driver Module provides PWM - controlled proportional outputs in a compact, robust form factor that is well suited to mobile mining applications.

The industry-standard CAN (Controller Area Network) connection provides a host PLC with the ability to control and monitor all outputs.

Uniquely Keyed Type A & Type B connector to prevent incorrect machine installation

Solenoid supply voltage to module from 8 to 24-volt d.c. (well suited to both 12-volt and 24 volt solenoids)

32 x PWM current-controlled proportional outputs (up to 1A continuous rating)

Module Type: Multi-channel Solenoid Driver

Supply Input: +8 VDC to +24VDC (+/-10%) / 800 Watts (Max) (based on output loads)

Data Communications: Pempek OBP CAN (A2)

Operating Temperature: -20°C to 70°C

Inputs: None

Outputs: 32 x PWM Current-regulated Outputs (1 A Maximum)

Connector 1: Pempek OBP A2 (CAN Bus)

Connector 2: Pempek OBP A59(PWM Outputs and Module Supply Input)

Connector 2: L0RE0201 Pempek OBP B59(PWM Outputs and Module Supply Input)



Connector Assembly

Part Number	Description
H0RE0201	Connector Assembly B59

L0RE0201 Pempek OBP Apitech Solenoid Module Type B

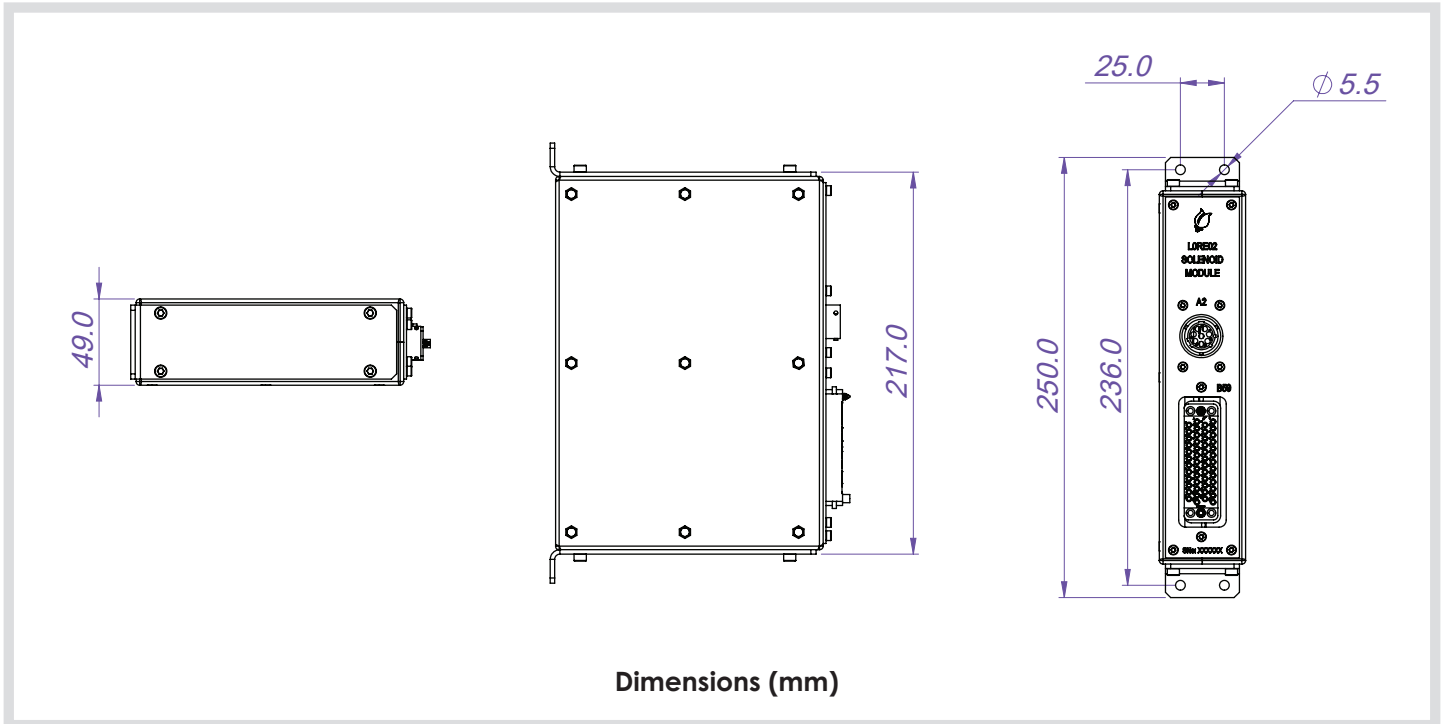

Dimensions (mm)

CONNECTOR A2

PIN	Connector A2 Burndy Female 8 Way	Signal
A2-A	Supply Input	24VDC Supply Input
A2-B	Supply Input	0VDC Supply Input
A2-C	CAN A (Positive)	Communications
A2-D	CAN A (Positive)	Communications
A2-E	CAN A (Negative)	Communications
A2-F	CAN A (Negative)	Communications
A2-G	Termination Link 1 - 1	Termination Link Input
A2-H	Termination Link 1 - 2	Termination Link Input



L0RE0201 Pempek OBP Apitech Solenoid Module Type B

CONNECTOR B59

Number	Unit / PCB GMCT50F Female Board Mount PIN	Name
1	A	
2	B	0VDC
3	C	MODULE-SEL-1
4	D	8-24VDC SUPPLY
5	E	
6	F	0VDC
7	H	0VDC
8	J	8-24VDC SUPPLY
9	K	SOL-1
10	L	SOL-2
11	M	MODULE-SEL-2
12	N	SOL-3
13	P	SOL-4
14	R	SOL-5
15	S	0VDC
16	T	SOL-6
17	U	SOL-7
18	V	SOL-8
19	W	MODULE-SEL-3
20	X	SOL-9
21	Y	SOL-10
22	Z	SOL-11
23	a	0VDC
24	b	SOL-12
25	c	SOL-13
26	d	SOL-14
27	e	
28	f	SOL-15
29	h	SOL-16
30	j	SOL-17
31	k	
32	m	SOL-18
33	n	SOL-19
34	p	SOL-20
35	r	
36	s	SOL-21
37	t	SOL-22
38	u	SOL-23
39	v	
40	w	SOL-24
41	x	SOL-25
42	y	SOL-26
43	z	
44	AA	SOL-27
45	BB	SOL-28
46	CC	SOL-29
47	DD	
48	EE	SOL-30
49	FF	SOL-31
50	HH	SOL-32

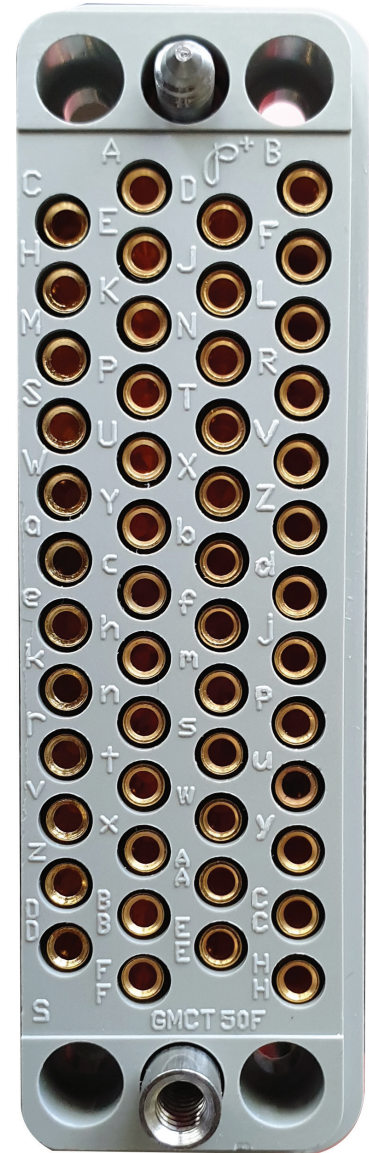

Image depict coding pins required