

L1200301 Pempek OBP Solenoid Module I/O All Digital Input 24VDC Type A

The L1200301 Pempek OBP module provides a robust compact general purpose I/O module that is designed and manufactured for mobile mining applications.

The module provides a variety of inputs and outputs and is ideal for driving solenoids and other outputs in a range of +8V to +26V.

The industry-standard CAN (Controller Area Network), connection provides a host PLC with the ability to control and monitor all outputs and input resources.

Module Primary board - A59_B0RE2

Module Secondary board - A47_B0R33



Specifications

- 20 x Digital Inputs (24 VDC)
- 18 x Analog Inputs (4 -20 mA)
- 32 x PWM current-controlled proportional outputs (up to 1A continuous rating)
- 4 x Frequency Counter Inputs (5 kHz Maximum)
- Uniquely Keyed Type A connector to prevent incorrect machine installation
- Supply Multi-purpose Inputs A47: +8 VDC to +24VDC (+10%) /3Watt (Max) for Internal Electronics
- Supply Input Solenoid Driver A59: +8 VDC to +24VDC (+10%) /3Watt (Max) for Internal Electronics
- Data Communications: Pempek OBP CAN (A2)
- Operating Temperature: -20°C to 70°C

L1200301 Pempek OBP Solenoid Module I/O All Digital Input 24VDC Type A

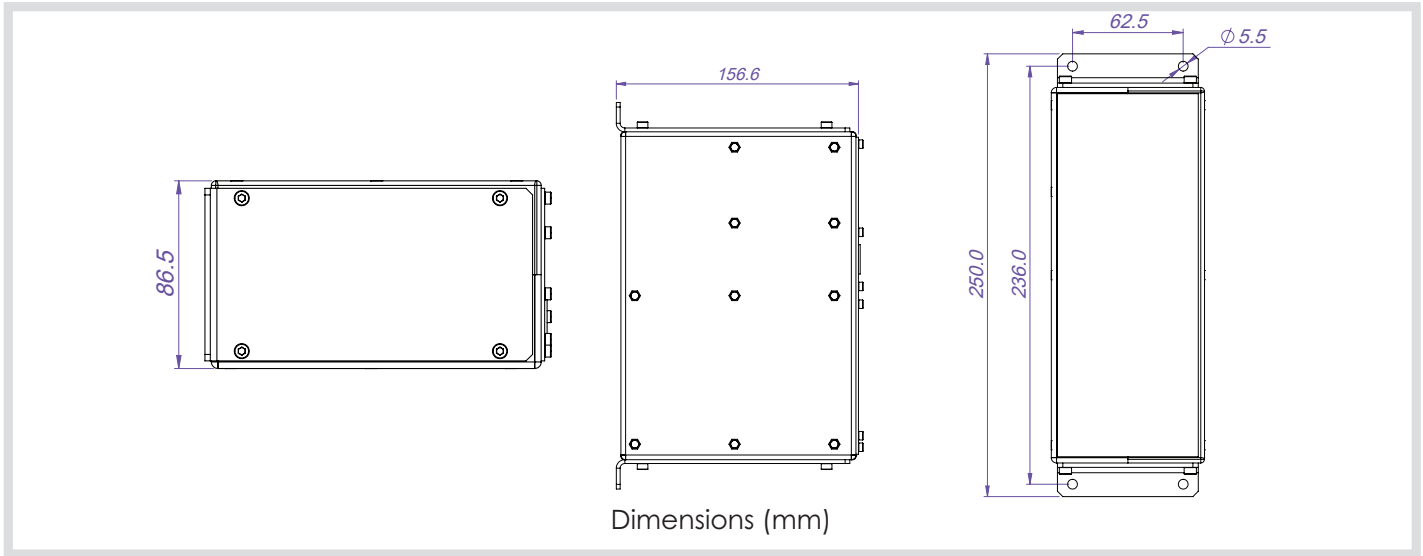

Facing Plate



CONNECTOR A2

Number	Unit / PCB	8 Pin Female Burndy	Name
1	A		
2	B	0Vdc	
3	C	CANH0	
4	D	CANH0	
5	E	CANL0	
6	F	CANL0	
7	G	L1-1	
8	H	L1-2	



L1200301 Pempek OBP Solenoid Module I/O All Digital Input 24VDC Type A

CONNECTOR A47

Number	Unit / PCB GAPL-50 Female Board Mount PIN	L1200301 Name
1	A	MODULE-SEL-1
2	B	24V Input Supply
3	C	0VDC
4	D	Quadrature Encoder A-Q1
5	E	MODULE-SEL-2
6	F	Quadrature Encoder A-Q2
7	H	0VDC
8	J	Quadrature Encoder B-Q1
9	K	MODULE-SEL-3
10	L	Quadrature Encoder B-Q2
11	M	24V-DINP-2
12	N	24V-DINP-1
13	P	24V-DINP-4
14	R	24V-DINP-3
15	S	24V-DINP-6
16	T	24V-DINP-5
17	U	24V-DINP-8
18	V	24V-DINP-7
19	W	24V-DINP-10
20	X	24V-DINP-9
21	Y	24V-DINP-12
22	Z	24V-DINP-11
23	a	ANALOG-2
24	b	ANALOG-1
25	c	ANALOG-4
26	d	ANALOG-3
27	e	ANALOG-6
28	f	ANALOG-5
29	h	ANALOG-8
30	j	ANALOG-7
31	k	ANALOG-10
32	m	ANALOG-9
33	n	ANALOG-12
34	p	ANALOG-11
35	r	ANALOG-14
36	s	ANALOG-13
37	t	ANALOG-16
38	u	ANALOG-15
39	v	ANALOG-18
40	w	ANALOG-17
41	x	0VDC Reference
42	y	EXTERNAL 24V PS(0.5A)
43	z	24V-DINP-14
44	AA	24V-DINP-13
45	BB	24V-DINP-16
46	CC	24V-DINP-15
47	DD	24V-DINP-18
48	EE	24V-DINP-17
49	FF	24V-DINP-20
50	HH	24V-DINP-19



L1200301 Pempek OBP Solenoid Module I/O All Digital Input 24VDC Type A

CONNECTOR A59

Number	Unit / PCB GAPL-50 Female Board Mount PIN	L1200301 Name
1	A	
2	B	0VDC
3	C	MODULE-SEL-1
4	D	8-24VDC SUPPLY
5	E	
6	F	0VDC
7	H	0VDC
8	J	8-24VDC SUPPLY
9	K	SOL-1
10	L	SOL-2
11	M	MODULE-SEL-2
12	N	SOL-3
13	P	SOL-4
14	R	SOL-5
15	S	0VDC
16	T	SOL-6
17	U	SOL-7
18	V	SOL-8
19	W	MODULE-SEL-3
20	X	SOL-9
21	Y	SOL-10
22	Z	SOL-11
23	a	0VDC
24	b	SOL-12
25	c	SOL-13
26	d	SOL-14
27	e	
28	f	SOL-15
29	h	SOL-16
30	j	SOL-17
31	k	
32	m	SOL-18
33	n	SOL-19
34	p	SOL-20
35	r	
36	s	SOL-21
37	t	SOL-22
38	u	SOL-23
39	v	
40	w	SOL-24
41	x	SOL-25
42	y	SOL-26
43	z	
44	AA	SOL-27
45	BB	SOL-28
46	CC	SOL-29
47	DD	
48	EE	SOL-30
49	FF	SOL-31
50	HH	SOL-32

