

## L1240101 AC Variable Frequency Drive 2-in-1 1140V 150kW - 24V Control PS - 110/220V Relay - 5V Encoder

Pempek's AC Variable Frequency Drive 2-in-1 frequency converter for high-performance control of 1140V induction motor in demanding industrial applications.

- Four quadrant operation with full regeneration
- Integrated pre-charging unit
- Integrated safety relay
- Isolated CAN interface with CANOpen protocol
- Two CAN connectors to enable daisy-chaining of bus.
- Method for externally setting the CAN Sub ID for the module
- Motor temperature monitoring
- Sophisticated direct torque control
- Sensorless vector speed control
- Maximum torque at zero speed
- Two-times of overload capability
- Water cooling required
- 24V control power

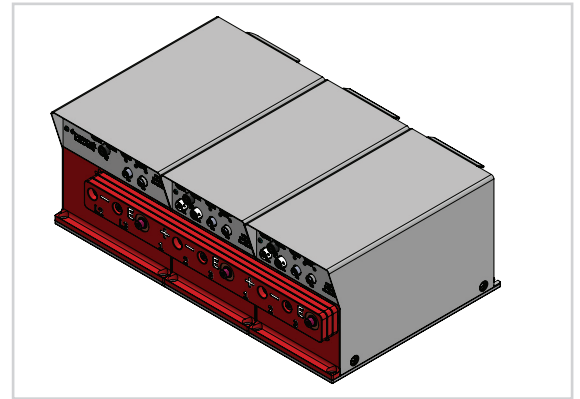

### Typical Application

- Continuous Bolter/Miners
- Longwall Shear
- Shuttle Car
- Continuous Haulage
- Mobile Bolters
- Mobile Roof Supports
- Remote Control Scoops
- Remote Control Loaders
- Any industrial AC Motor application within power specification

### Specification Chart

Pempek VFD	VFD rated voltage	Max current	Suitable motor Max power @1140V	Suitable motor Max power @960V	Suitable motor Max power @860V	Suitable motor Max power @660V	Suitable motor Max power @460V	Suitable motor Max power @380V	Dimension
LOW4	1140V	200A	150KW	133KW	119KW	91KW	64KW	52KW	462x372x200
LOTJ	1140V	300A	230KW	200KW	178KW	178KW	137KW	79KW	610x370x213
LOUP	480V	500A	NA	NA	NA	228KW	159KW	130KW	700x325x168
L11W	660V	500A	NA	NA	NA	228KW	159KW	130KW	430x350x201
L124	1140V	400A	150KW x2	133KW x2	119KW x2	91KW x2	64KW x2	52KW x2	562x350x200
L127	1140V	400A	150KW x3	133KW x3	119KW x3	91KW x3	64KW x3	52KW x3	733x350x200

## L1240101 AC Variable Frequency Drive 2-in-1 1140V 150kW - 24V Control PS - 110/220V Relay - 5V Encoder

### Dimensional Drawings (mm)

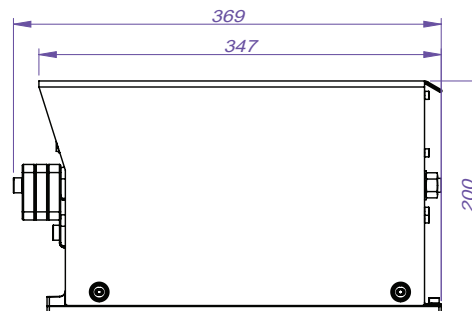
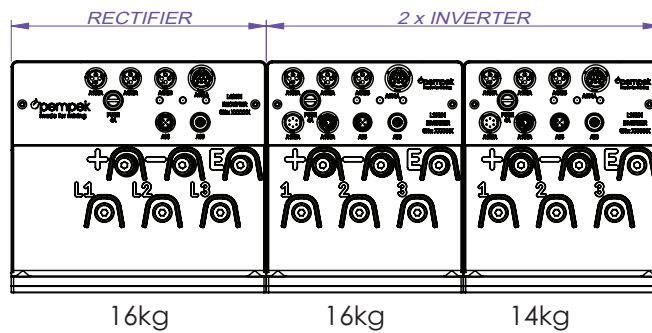
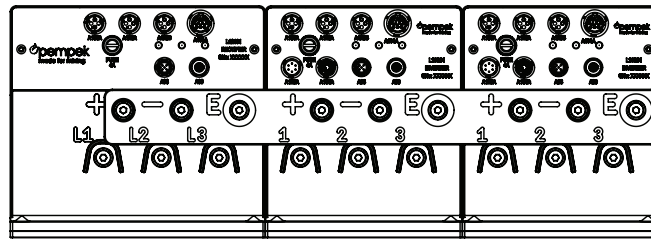
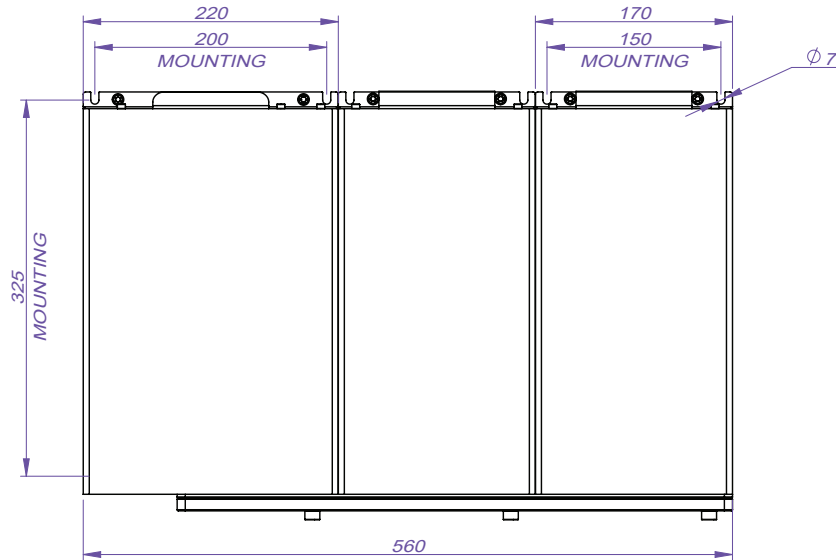

**Total Weight – 44kg**

## L1240101 AC Variable Frequency Drive 2-in-1 1140V 150kW - 24V Control PS - 110/220V Relay - 5V Encoder

### 2-in-1 Drive Typical Application Example

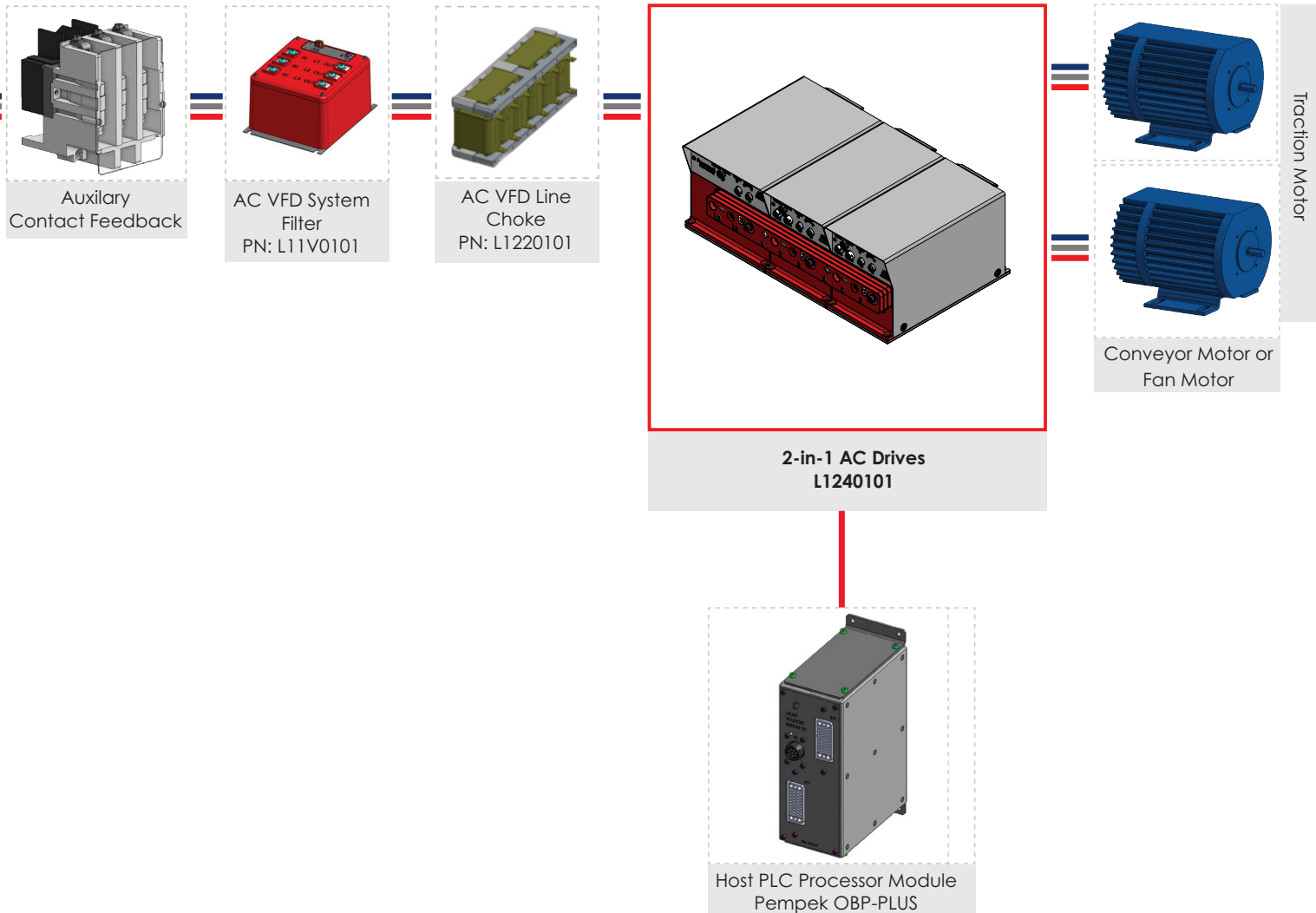

### Ordering Information

AC Variable Frequency Drive 2-in-1 1140V 150kW - 24V Control PS - 110/220V Relay - 5V Encoder

**Part Number: L1240101**

AC VFD System Filter with Common Mode Choke (1140 V) **Part Number: L11V0101**

AC VFD Line Choke **Part Number: L1220101**